

JS-20 MX100 Scan Head

JoeScan

Technical Specifications Data Sheet

3-D Vision Profiling

Product Overview

The JS-20 MX100 uses JoeScan's newest optimization scanning technology that allows it to operate accurately in full sunlight. This single-laser scanner delivers fast and accurate measurements operating in light levels at least as strong as 100,000 lux.

Easy to Use: The MX100 is based on JoeScan's proven and reliable JS-20 scanner platform, developed to make scanning systems easier to install and maintain. It requires only 24VDC and an Ethernet connection for operation, and it can be installed in any orientation in minutes using the optional Mount Kit.

Because the scanner uses an Ethernet interface, it is easy to communicate with the scanner without special hardware or proprietary software. This interface also allows users to view real-time profile data and camera images, and to configure and calibrate the scanner using a simple Web browser on their PC.

Power input to the scanner is via the Switchcraft EN3 (8-pin) connector. This connector can also be used to connect and synchronize the scan head with other production line components and optimizer programs.

The MX100 is fully compatible with all scanners in the JS-20 family. All scanners use JoeScan's reliable QuickPulse laser technology, which keeps all scan heads synchronized and helps maximize the laser life.

Fast & Accurate: The MX100 is one of the fastest and most accurate scanners on the market today. It can make up to 138 profile measurements per second, with each profile containing up to 122 data points. Measurement accuracy ranges from +/- 0.025" (at 20" standoff) to +/- 0.040" (at 54" standoff).

Rugged & Reliable: Like all JoeScan products, this model is designed vibration, and the aluminum for the most challenging environments. It withstands extreme housing is fully sealed to keep out dust and moisture.

The JS-20 MX100 is designed to operate in full sunlight. It is ideally suited for use in log yards during sorting and bucking operations.

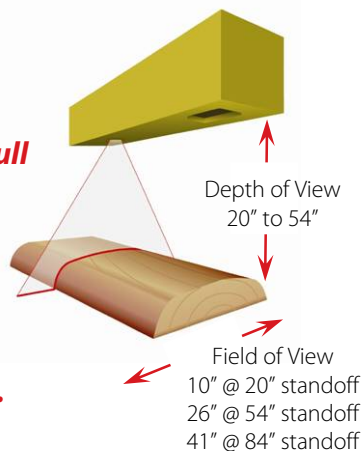

Key Features

- 100mW laser
- Extended depth-of-view range to 84"
- Scan rate up to 138 profiles per second
- Scan resolution up to +/- 0.025"
- Easy-to-use Ethernet interface
- One-click, automatic calibration
- Encoder-synchronized scanning
- Rugged, fully sealed aluminum housing
- Image View feature for easy troubleshooting
- 5-year defect warranty & 10-year support life guarantee

Typical Applications

- Outdoor applications using lineally scanned bucking or merchandising optimizers.

JS-20 MX100 Scan Head

Product Dimensions

(All dimensions in inches)

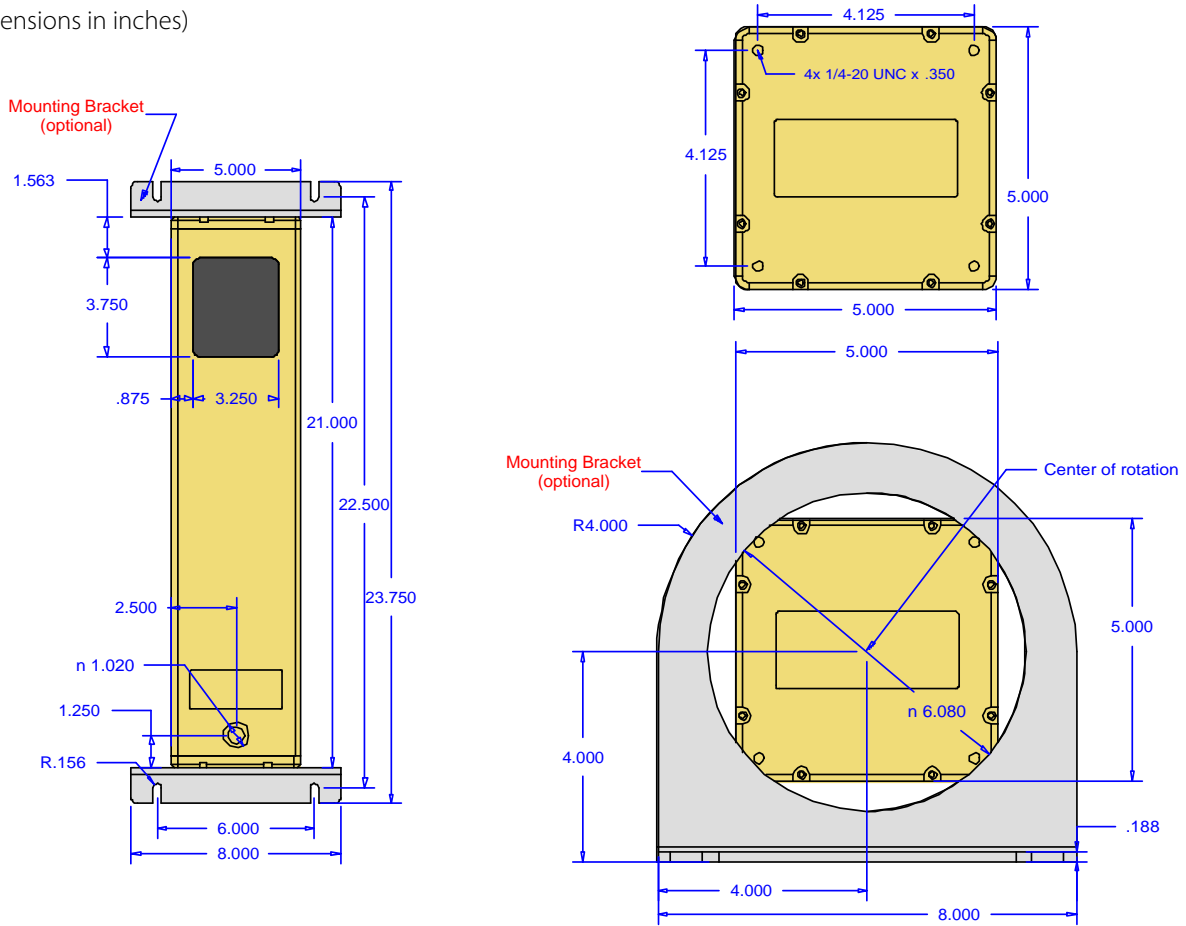

Field-of-View Details

(All dimensions in inches)

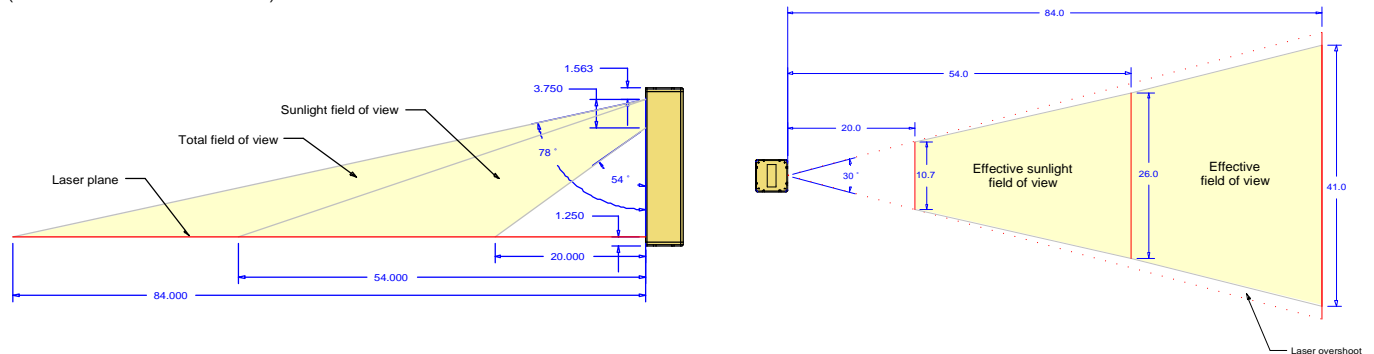

JS-20 MX100 Scan Head

Mounting Guidelines

- An optional Mount Kit is available for this product.
- Attach brackets by inserting stainless 1/4-20 x 1/2" screws into the four threaded holes on each end of the scanner.
- Maintain minimum clearances from the ends of the scanner (including brackets & screws) as shown below.



Using the Optional Mount Kit

Kit Contents

- (2) scanner brackets
- (8) stainless screws 1/4-20 x 1/2"

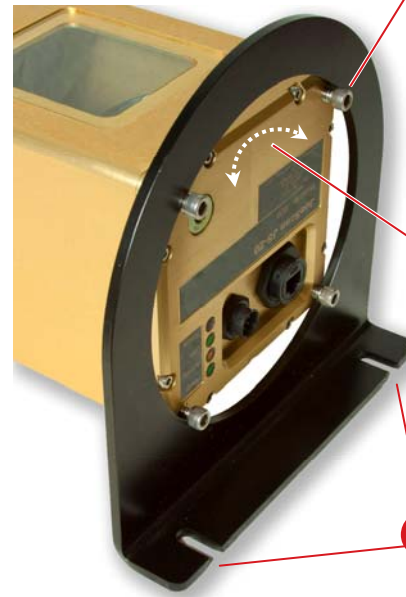

- 1 Loosely attach each bracket using four stainless screws.
Note: Screws are inserted inside the bracket; screw head holds the bracket in place.
- 2 Rotate scanner to the desired orientation; then tighten screws to secure in place.
- 3 Secure bracket to solid mounting surface using 5/16"-diameter bolts (not provided).

Product Warranty & Support

JoeScan products are proven to be durable and reliable. This allows JoeScan to offer the best warranty and support in the industry.

All products are covered by a **5-year warranty*** that begins when the product ships from JoeScan. If a scan head is found to be faulty, JoeScan will either repair or replace the product at no charge. JoeScan also promises to make the necessary warranty repairs within three days of receiving a defective product.

In addition, all scan heads are covered by an exclusive **10-year product support guarantee**. This means that JoeScan will continue to provide parts and service for the product for 10 years or longer.

Additional warranty details and instructions are available on the JoeScan Web site.

*Warranty is limited to product defects and damage caused by normal wear and tear. It does not cover damage caused by accidents or improper use.

JoeScan offers the best warranty and support in the industry.

The 5-year warranty helps eliminate unexpected maintenance costs and promises that repairs will be made quickly. JoeScan adds to that a 10-year product support guarantee to ensure that each scan head can provide years of service.

JS-20 MX100 Scan Head

Product Specifications

General

Dimensions	21" x 5" x 5"
Weight	12 lbs
Laser Type & Color	Pulsed, Class IIIb – visible red
User Interface	PC
Data Interface	10/100BaseT Ethernet

System Performance

Depth of View	20" to 54" with extended range to 84" *
Field of View	10" @ 20" standoff 26" @ 54" standoff 41" @ 84" standoff
Accuracy	+/- 0.025" @ 20" standoff +/- 0.040" @ 54" standoff
Scan Rate	Up to 138 profiles/sec
Data Density	20 points/inch at 20" standoff 9 points/inch at 54" standoff
Number of Data Points	243

(*When using extended range, color of product being scanned may reduce scanner's performance and ambient light immunity.)

Environmental

Operating Temp	-20° to 50°C (0° to 120°F)
Lighting	Fully operational in complete darkness, indoor lighting or with direct sunlight in the field of view; cannot be pointed directly into the sun.

Power Supply

Voltage Range	20 - 28VDC
Max Current	0.35A @ 24VDC
Voltage Ripple	< 5Vpp

Quadrature Encoder/Start Scan Inputs

Primary Signaling Standard	RS-422 differential
Alternate Signaling	Open collector on '+' channel (+ channels have built-in 2k pull-up to 5V)
Input Voltage Range	0 - 5VDC
Max Encoder Rate	100,000 pulses per second (differential)

PC Requirements

The diagnostic and calibration software (JSdiag) will run on any operating system with Java 1.5™ installed, including MS Windows™, Mac OS X™, Linux, Sun Solaris™ and others.

Optional Accessories

JS-20 Control Cable (Switchcraft EN3 8-wire)
LTW Sealed Ethernet Cable
Mount Kit

Switchcraft EN3® Connector

Wire Color	Pin	Function
White	1	Encoder B -
Green	2	Encoder B +
White/Black	3	Start Scan -
White/Red	4	Start Scan +
White/Yellow	5	Encoder A -
White/Green	6	Encoder A +
Black	7	Ground
Red	8	+24VDC

Warranty/Support

5-year product warranty (free repair or replacement of defective products)

10-year support guarantee for parts & service



Illustrations, descriptions and technical specifications are not binding and are subject to change without notice.

JoeScan, Inc.

4510 NE 68th Drive, Suite 124
Vancouver, WA 98661 USA
Tel 360.993.0069
support@joescan.com
www.joescan.com

JoeScan